

Unique Flange PE100

patented, for PN 10, PN 16 and PN 25 piping systems

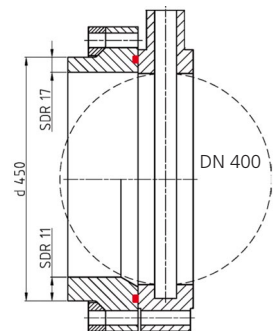

- The PE Unique Flange is designed as a fixed flange and is fitted with a loose flange. This allows the valve to be selected one dimension smaller than with a conventional loose flange connection which reduces the risk of deposit-build-up thereby cutting project costs.
- for direct and misalignment-free connection of PE pipes to metal valves without loss of cross section and without reduction of nominal diameters
- this enables the connection of plastic pipes to metal valves with the same nominal size and pressure class
- identical cross section improves the flow properties, reduces dead space and the risk of deposits, enables also pigging and the use of butterfly valves without being obstructed by the flange adaptor
- PE 100 Unique Flanges are with integrated loose epoxy-coated ductile iron flange DIN EN 1092-1 PN 10 and PN 16, PN 25 available upon request
- with extended fusion spigot for electrofusion DVGW approved Register No. DVGW PE part
 - DV-8606 BT0423, OD 75 mm to OD 225 mm
 - DV-8611 BT0424, OD 250 mm to OD 630 mm
- optional flanges: stainless steel, galvanised, with flat sealing surface and without flute and O-ring, slotted holes, PN 25
- a integrated O-ring provides maximum safety, the O-ring already seals at low tightening torques. Standard tightening avalues increase safety (see DVS 2210-1 Sheet 3 Table 5). Optionally with a flat profile gasket.
- externally de-beaded on request
- **cost saving as a valve can be selected one nominal diameter smaller than otherwise**

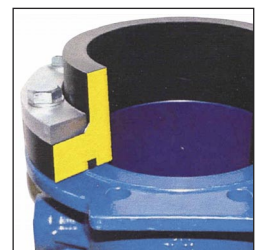

Connection with Unique Flange

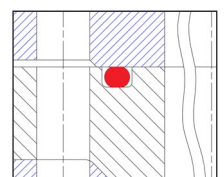

O-ring pressureless

Conventional connection

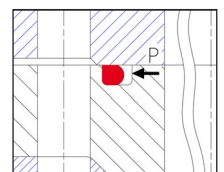

O-ring deformed under pressure

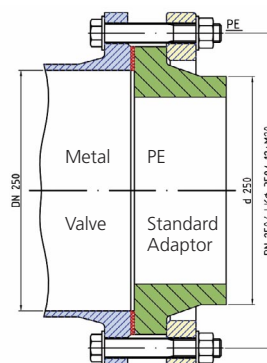
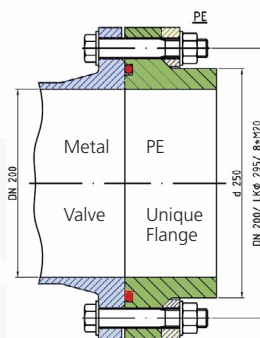

Unique Flange PE100

Trouble-free connection to valves

Our Unique flange allow the connection of PE pipes to steel or cast iron valves without changing the nominal diameter. This considerably reduces the total cost.

A connection without offset

- improves the flow characteristics
- reduces deposit buildup
- allows pigging
- permits use of butterfly valves

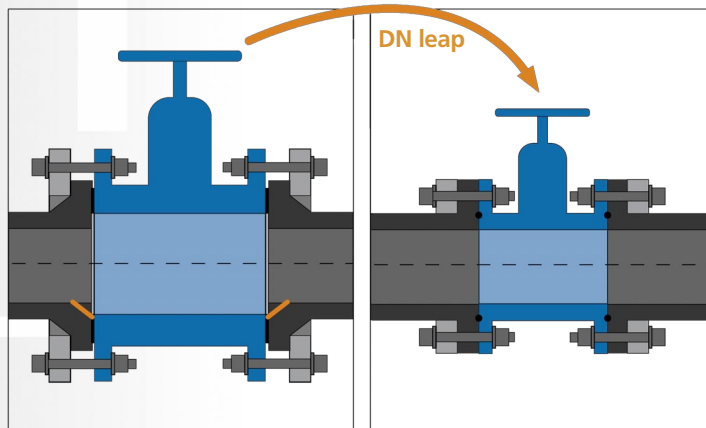

da	SDR 17		SDR 11	
	160	HP (DN 150)	HP (DN 150)*	UF (DN 125)
180	HP (DN 150)		HP (DN 150)	
200	HP (DN 200)*	UF (DN 150)	UF (DN 150)	
225	HP (DN 200)		HP (DN 200)*	
250	HP (DN 250)*	UF (DN 200)	UF (DN 200)	
280	HP (DN 250)		HP (DN 250)*	
315	HP (DN 300)*	UF (DN 250)	UF (DN 250)	
355	UF (DN 300)		UF (DN 300)	
450	UF (DN 400)		UF (DN 400)	
560	UF (DN 500)		UF (DN 500)	
630	UF (DN 500)		UF (DN 500)	
> 630	UF		UF	

HP Flange	UF Unique flange
-----------	------------------

Optimal flange to valve connection

The ideal combination can be found in the adjacent table.

In some cases a HP Flange as well as a Unique Flange can be installed.

For connections above OD 355 mm we recommend using our Unique Flange instead of a traditional flange connection.

For a dead space or misalignment reduced connection to a valve, please inquire using "to valve connection".

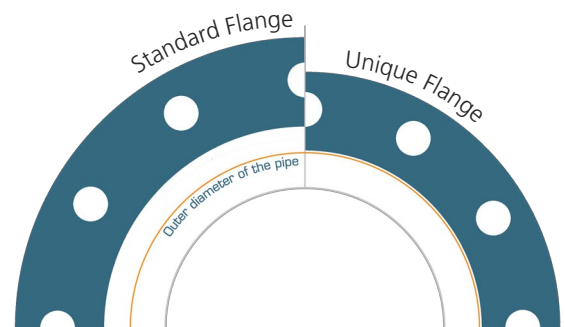

When using a bolt circle with the same PE pipe dimension, the Unique Flange reduces the standard bolt circle by one DN

Unique Flange PE100 Minimize project costs

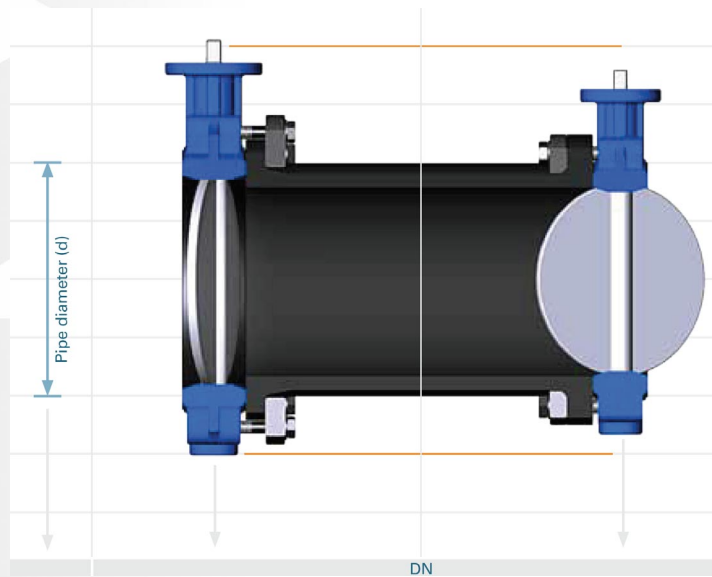

Noticeably higher savings are possible with very large pipe diameters

Cost reduction due to the reduced DN stage, the project costs are reduced considerably. For example a DN 300 Unique Flange can be used and thus also DN 300 fittings in a d 355 mm PE pipeline. In addition to the technical advantage of the Unique Flange also approx. 45% of the total installation costs will be saved.

Advantages of our Unique Flange

- Cost savings
- high security
- good flow characteristics
- unobstructed valve discs

d	DN	
	DIN-/ISO-/HP-flange	UF Unique Flange
200	200	150
225	200	
250	250	200
280	250	
315	300	250
355	350	300
400	400	350
450	500	400
500	500	400
560	600	500
630	600	500
710	700	600
800	800	700
900	900	800
1000	1000	900
1200	1200	1000
1400	1400	1300
1600	1600	1500
1800	1800	1600
2000	2000	1800

Unique Flange PE100

Minimize project costs

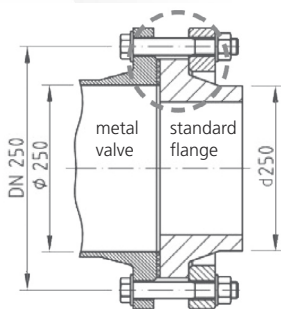

- bolt holes match, internal misalignment risk of turbulences/sedimentation due to reduced internal diameters

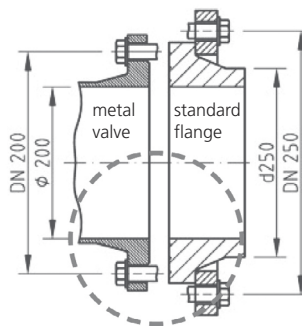

- bolt holes do not match, no connection possible
- using Unique Flange the internal diameters match

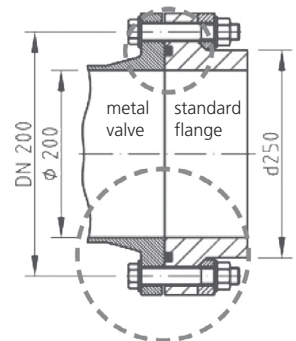

- bolt holes match
- internal diameter match, no misalignment

Unique Flange PE100 PN 10

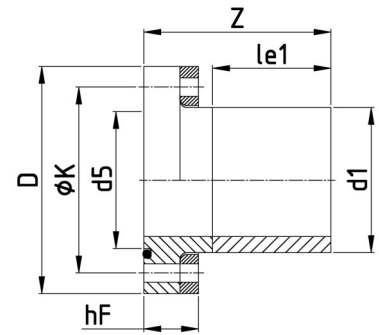

- with EPDM O-ring
- flange steel plastic coated DIN EN 1092-1 PN 10
- long fusion spigot for electrofusion

Optionally flanges stainless steel, hot dipped galvanised
flat sealing surface without flute and O-ring
PE adaptor with slotted holes for perfect flange alignment, PN 25

DN	d ₁	d ₅	l _{e1}	ØK	n x ØL	Bolts	D	hF		Z		weight in kg	
								SDR 17	SDR 11	SDR 17	SDR 11	SDR 17	SDR 11
65	90	90	200	145	8x18	M16	185	36	36	255	255	3,0	3,2
80	110	105	200	160	8x18	M16	200	48	48	300	300	3,9	4,2
100	140	132	200	180	8x18	M16	220	38	43	260	260	3,3	4,7
125	160	157	200	210	8x18	M16	250	38	43	265	270	5,0	5,8
125	180	157	200	210	8x18	M16	250	38	43	315	315	6,2	6,5
150	200	183	200	240	8x23	M20	285	43	48	260	265	6,4	7,4
200	250	235	200	295	8x23	M20	340	43	53	260	270	6,6	10,8
250	315	291	200	350	12x23	M20	395	49	54	310	320	13,2	15,5
300	355	330	200	400	12x23	M20	445	55	65	270	280	15,1	19,0
350	400	393	300	460	16x23	M20	505	64	74	375	385	24,8	31,2
400	450	445	300	515	16x27	M24	565	66	81	375	390	31,6	40,2
400	500	445	300	515	16x27	M24	565	66	81	570	590	42,5	56,3
400	450	490	300	565	20x27	M24	615	74	88	375	400	49,3	38,4
500	560	546	300	620	20x27	M24	670	76	96	385	405	46,4	60,7
500	630	546	300	620	20x27	M24	670	76	96	590	610	64,8	87,3
600	710	643	500	725	20x30	M27	780	86	106	800	820	106,0	142,0
700	800	750	500	840	24x30	M27	895	6	118	800	820	130,0	177,0
800	900	870	500	950	24x33	M30	1015	105	130	820	840	176,0	238,0
900	1000	960	500	1050	28x33	M30	1115	114	134	840	860	232,0	296,0
1000	1200	1060	500	1160	28x36	M33	1230	129	154	930	890	344,0	472,0

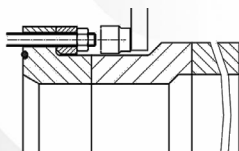

Standard for wrench

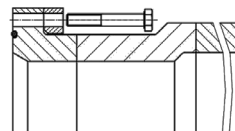

Extra long for bolt

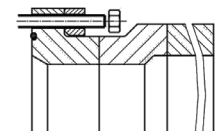

Extra short for open-end spanner

Options SDR 11

DN	d ₁	Z extra long	Z extra short
500	630	860	560
600	710	920	770
700	800	910	740
800	900	960	730
900	1000	970	760
1000	1200	1030	850

Options SDR 17

DN	d ₁	Z extra long	Z extra short
500	630	860	560
600	710	920	770
700	800	910	740
800	900	960	730
900	1000	970	760
1000	1200	1080	850

Unique Flange PE100 PN 16

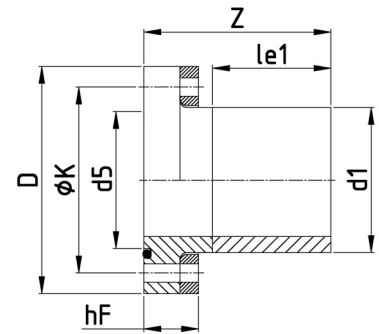

- with EPDM O-ring
- flange steel plastic coated DIN EN 1092-1 PN 16
- long fusion spigot for electrofusion

Optionally flanges stainless steel, hot dipped galvanised
flat sealing surface without flute and O-ring
PE adaptor with slotted holes for perfect flange alignment, PN 25

DN	d ₁	d ₅	l _{e1}	ØK	n x ØL	Bolts	D	hF		Z		weight in kg	
								SDR 17	SDR 11	SDR 17	SDR 11	SDR 17	SDR 11
65	90	90	200	145	8x18	M16	185	36	36	255	255	3,0	3,2
80	110	105	200	160	8x18	M16	200	48	48	300	300	3,9	4,2
100	140	132	200	180	8x18	M16	220	38	43	260	260	3,3	4,7
125	160	157	200	210	8x18	M16	250	38	43	265	270	5,0	5,8
125	180	157	200	210	8x18	M16	250	38	43	315	315	6,2	6,5
150	200	183	200	240	8x23	M20	285	43	48	260	265	6,4	7,4
200	250	235	200	295	8x23	M20	340	43	53	260	270	6,6	10,8
250	315	291	200	350	12x23	M20	395	49	54	310	320	13,2	15,5
300	355	330	200	400	12x23	M20	445	55	65	270	280	15,1	19,0
350	400	393	300	460	16x23	M20	505	64	74	375	385	24,8	31,2
400	450	445	300	515	16x27	M24	565	66	81	375	390	31,6	40,2
400	500	445	300	515	16x27	M24	565	66	81	570	590	42,5	56,3
400	450	490	300	565	20x27	M24	615	74	88	375	400	49,3	38,4
500	560	546	300	620	20x27	M24	670	76	96	385	405	46,4	60,7
500	630	546	300	620	20x27	M24	670	76	96	590	610	64,8	87,3
600	710	643	500	725	20x30	M27	780	86	106	800	820	106,0	142,0
700	800	750	500	840	24x30	M27	895	6	118	800	820	130,0	177,0
800	900	870	500	950	24x33	M30	1015	105	130	820	840	176,0	238,0
900	1000	960	500	1050	28x33	M30	1115	114	134	840	860	232,0	296,0
1000	1200	1060	500	1160	28x36	M33	1230	129	154	930	890	344,0	472,0

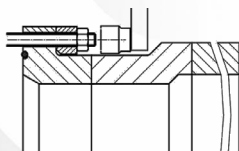

Standard for wrench

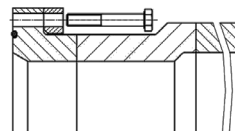

Extra long for bold

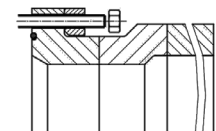

Extra short for open-end spanner

Options SDR 11

DN	d ₁	Z extra long	Z extra short
500	630	860	560
600	710		790
700	800	990	810
800	900	1030	830
900	1000	1060	850
1000	1200	1130	910

Options SDR 17

DN	d ₁	Z extra long	Z extra short
500	630	860	560
600	710		790
700	800	990	810
800	900	1030	830
900	1000	1060	850
1000	1200	1090	870